

r.LiNK Video-inserter

RL2-N902

Compatible with Opel vehicles with Navi 900 IntelliLink navigation system with 8" touch monitor and Chevrolet vehicles with MyLink IO6 system



Video-inserter for rear-view camera input and two additional video sources

Product features

- Video-inserter for factory-infotainment systems
- 2 CVBS video-inputs for after-market devices (e.g. DVD-Player, DVB-T tuner)
- FBAS Rear-view camera video-input
- Automatic switching to rear-view camera input on engagement of the reverse gear
- Activatable parking guide lines for rear-view camera (not available on all vehicles)
- Video-in-motion in drive mode (ONLY for connected video-sources)
- Video inputs NTSC and PAL compatible

Contents

1. Prior to installation

- 1.1. Delivery contents
- 1.2. Checking the compatibility of vehicle and accessories
- 1.3. Connectors – video interface
- 1.4. Dip-switch settings – video interface
 - 1.4.1. Enabling the interface's video inputs (dip 2-3)
 - 1.4.2. Rear-view camera setting (dip 5)
 - 1.4.3. Monitor adjustment (dip 8)
- 1.5. Connectors – CAN box
 - 1.5.1. Dip switch settings – CAN box

2. Installation

- 2.1. Place of installation
- 2.2. Connection schema
- 2.3. Connecting - PNP power / CAN cable
- 2.4. Connection – picture signal cable
- 2.5. Connecting video sources
 - 2.5.1. After-market rear-view camera
 - 2.5.1.1. Case 1: CAN-box receives the reverse gear signal
 - 2.5.1.2. Case 2: CAN-box does not receive the reverse gear signal
 - 2.5.2. Audio-insertion
- 2.6. Connecting video-interface and keypad
- 2.7. Picture settings and guide lines

3. Switching the video sources

- 3.1. By infotainment buttons
- 3.2. By external keypad

4. Specifications

5. Frequently asked questions

6. Technical support

Legal Information

By law, watching moving pictures while driving is prohibited, the driver must not be distracted. We do not accept any liability for material damage or personal injury resulting, directly or indirectly, from installation or operation of this product. This product should only be used while standing or to display fixed menus or rear-view-camera video when the vehicle is moving, for example the MP3 menu for DVD upgrades.

Changes/updates of the vehicle's software can cause malfunctions of the interface. We offer free software-updates for our interfaces for one year after purchase. To receive a free update, the interface must be sent in at own cost. Labor cost for and other expenses involved with the software-updates will not be refunded.

1. Prior to installation

Read the manual prior to installation.

Technical knowledge is necessary for installation. The place of installation must be free of moisture and away from heat sources.

1.1. Delivery contents

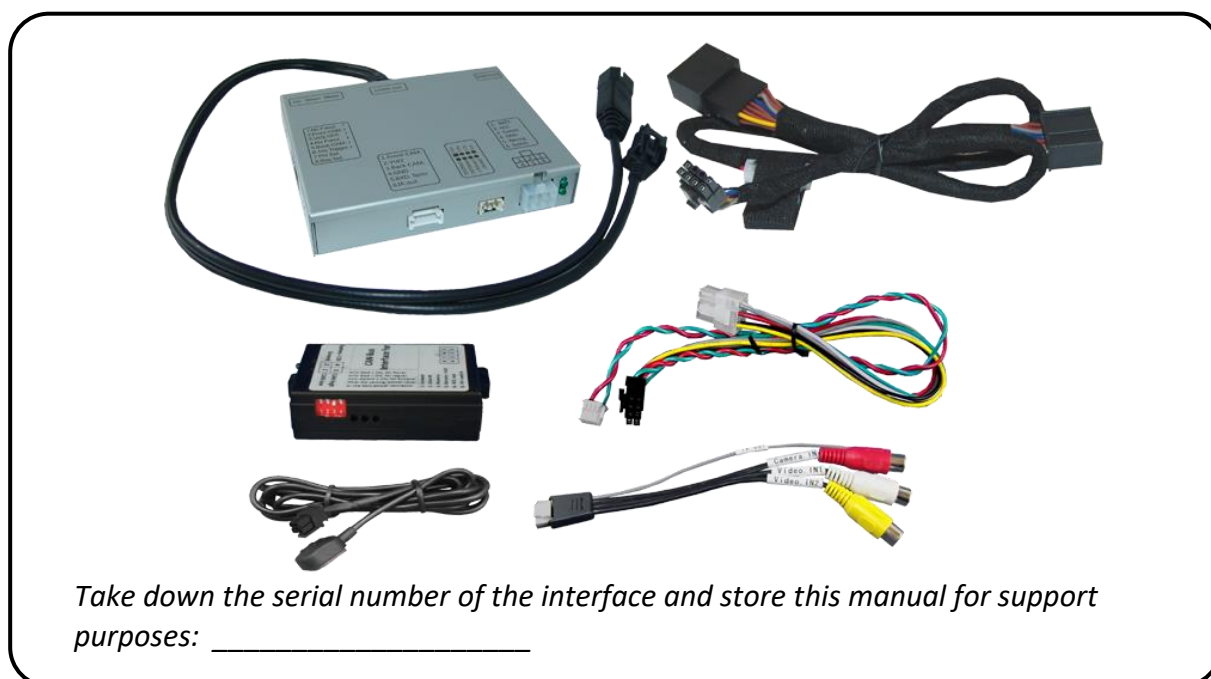

1.2. Checking the compatibility of vehicle and accessories

Compatibility		
Brand	Compatible vehicles	infotainment systems
Opel	Astra K (Sports Tourer und 5-Türer)- Modelljahre ab 2016 Insignia A Modelljahre 2014-2016 Insignia B Modelljahre ab 2017, Mokka X Modelljahre ab 2016	Navi 900 intelliLink with 8inch touch monitor (Gen. 1 und 2)
Chevrolet	Camaro from model year 2016 Corvette C7 model years 2014-2018	MyLink IO6 with 8inch monitor with separate radio-box

Limitations

Video only The interface inserts ONLY video signals into the infotainment. For inserting Audio signals either the possibly existing factory audio-AUX-input or a FM-modulator can be used. If 2 audio sources shall be connected to the infotainment, an additional electronic is necessary to switch them.

Factory rear-view camera Automatically switching-back from inserted video to factory rear-view camera is only possible while the reverse gear is engaged. To delay the switch-back an additional electronic part is required.

Guide lines If the CAN-box does not receive the required information from the vehicle CAN-bus, the guide-lines will not be supported.

1.3. Connectors – video interface

The video-interface converts the video signals of connected after-market sources in a factory monitor compatible picture signal which is inserted in the factory monitor, by using separate trigger options.

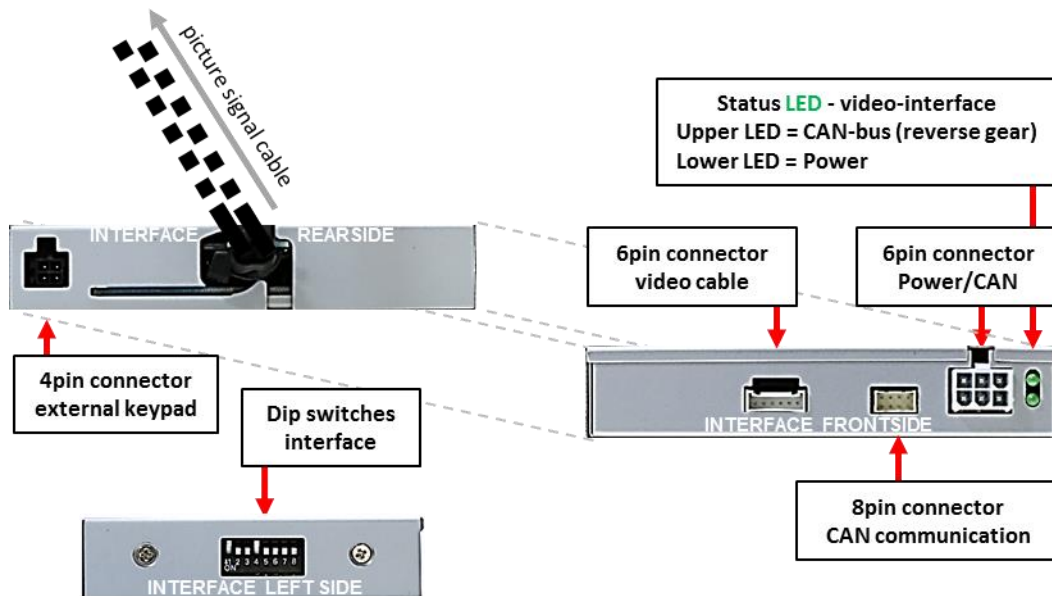

1.4. Dip-switch settings – video interface

Some settings must be selected by the dip-switches on the video-interface. Dip position down is ON and position up is OFF.



Dip	Function	ON (down)	OFF (up)
1	No function	-	set to OFF
2	CVBS AV1-input	enabled	disabled
3	CVBS AV2-input	enabled	disabled
4	No function	-	set to OFF
5	Rear-view cam type	after-market	factory or none
6	No function		set to OFF
7	No function		set to OFF
8	Monitor adjustments	8inch monitor	10inch monitor

After each Dip-switch-change a power-reset of the Can-box has to be performed!

See following chapters for detailed information.

1.4.1. Enabling the interface’s video inputs (dip 2-3)

Only the enabled video inputs can be accessed when switching through the interface’s video sources. It is recommended to enable only the required inputs, disabled inputs will be skipped when switching through the video-interfaces inputs.

1.4.2. Rear-view camera setting (dip 5)

If set to OFF, the interface switches to factory picture while the reverse gear is engaged to display factory rear-view camera.

If set to ON, the interface switches to its rear-view camera input „Camera-IN“ while the reverse gear is engaged.

1.4.3. Monitor adjustments (dip 8)

Dip switch setting ON supports all vehicles with 8inch monitor.

Dip switch setting OFF is for all vehicles with 10inch monitor.

Note: Dip 1, 4, 6 and 7 are out of function and have to be set to **OFF**.

1.5. Connectors – CAN box

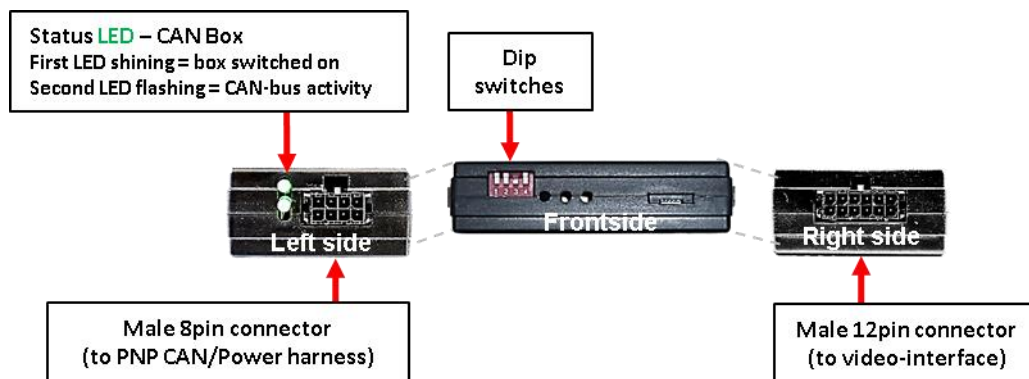

1.5.1. Dip-switch settings – CAN box

Some settings have to be selected by the dip-switches of the CAN box. Dip position “down” is ON and position “up” is OFF.

Fahrzeug/Navigation	Dip 1	Dip 2	Dip 3	Dip 4
All vehicles	OFF	OFF	OFF	OFF

After each Dip-switch-change a power-reset of the Can-box has to be performed!

2. Installation

To install the interface, first switch off the ignition and disconnect the vehicle's battery. Please read the owner's manual of the car, regarding the battery's disconnection! If required, enable the car's Sleep-mode (hibernation mode)

In case the sleep-mode does not succeed, the disconnection of the battery can be done with a resistor lead.

If the necessary stabilized power supply for the interface is not taken directly from the battery, the chosen connection has to be checked for being constantly stable.

The interface needs a permanent 12V source!

Note: Before a final installation, we recommend a test-run to ensure the compatibility of the vehicle and the interface.

Due to changes in the production of the vehicle manufacturer there's always a possibility of incompatibility.

2.1. Place of installation

The interface is built to be connected at the factory navigation blackbox.

The Built-in Locations of the factory navigation blackbox may vary, even in one and the same vehicle's series! Please ask for the manufacturer's information to avoid removing the wrong parts.

- The **Opel Mokka X** blackbox is usually to be found **behind the infotainment and navigation monitor**.
- The **Opel Astra K** blackbox should be found directly **behind the instruments**, like shown below.
- The **Corvette** HMI module is located in the **driver's footwell in front of the A-pillar**.

Other built-in locations of the blackbox like in in the passenger's foot well in front of the A-pillar or even behind or near the glove box are possible.

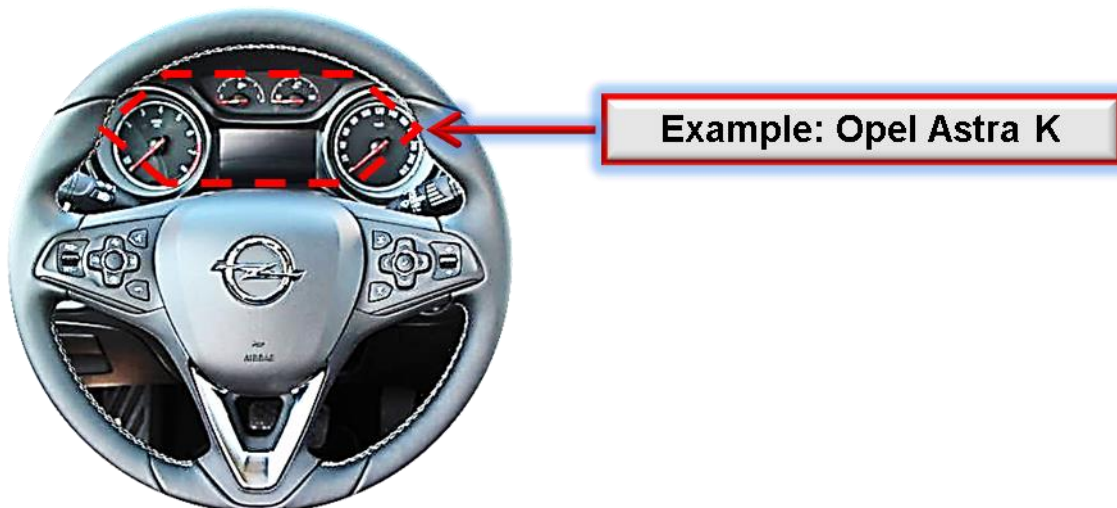

2.2. Connection schema

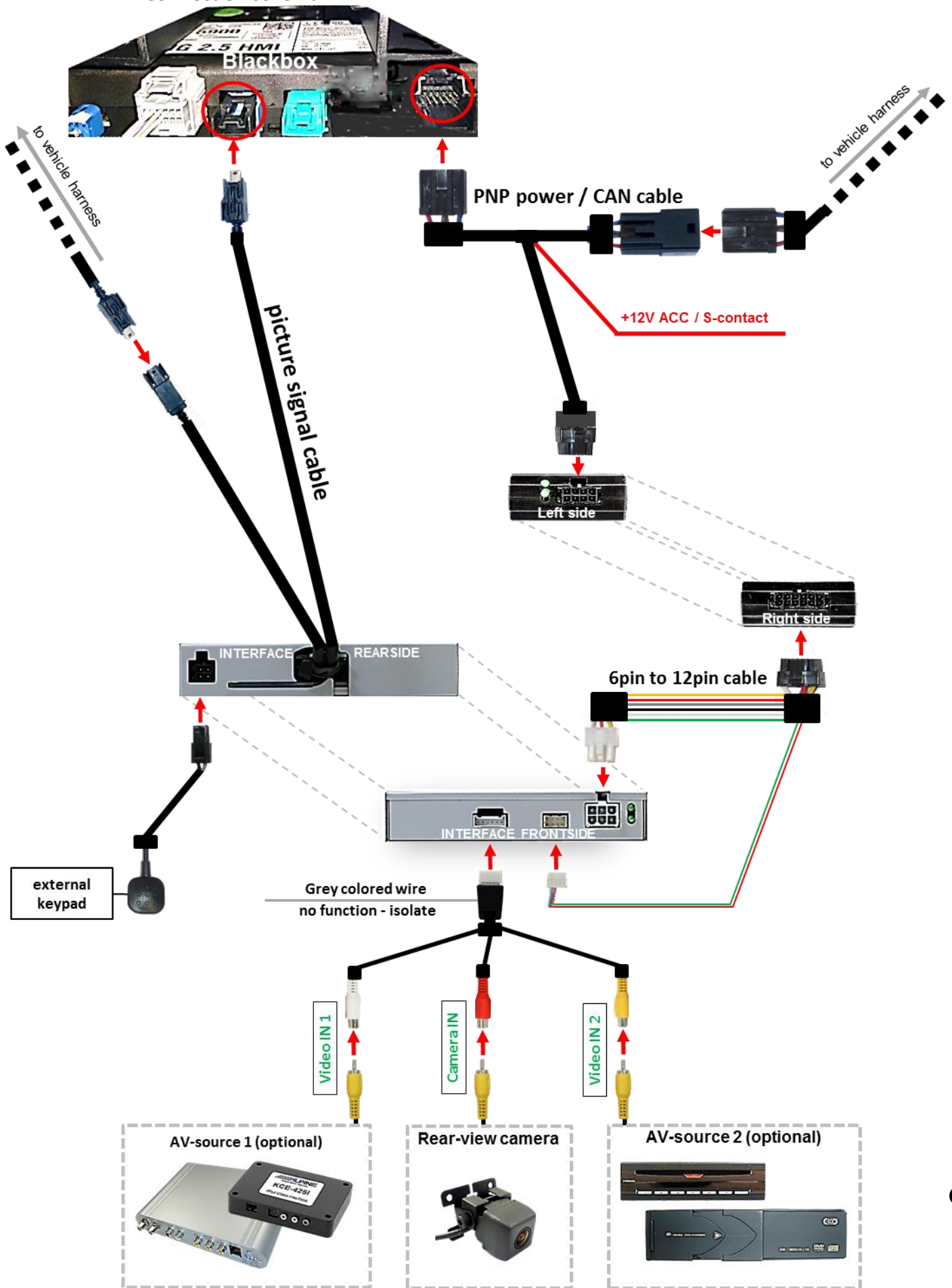

2.3. Connection - PNP Power / CAN cable

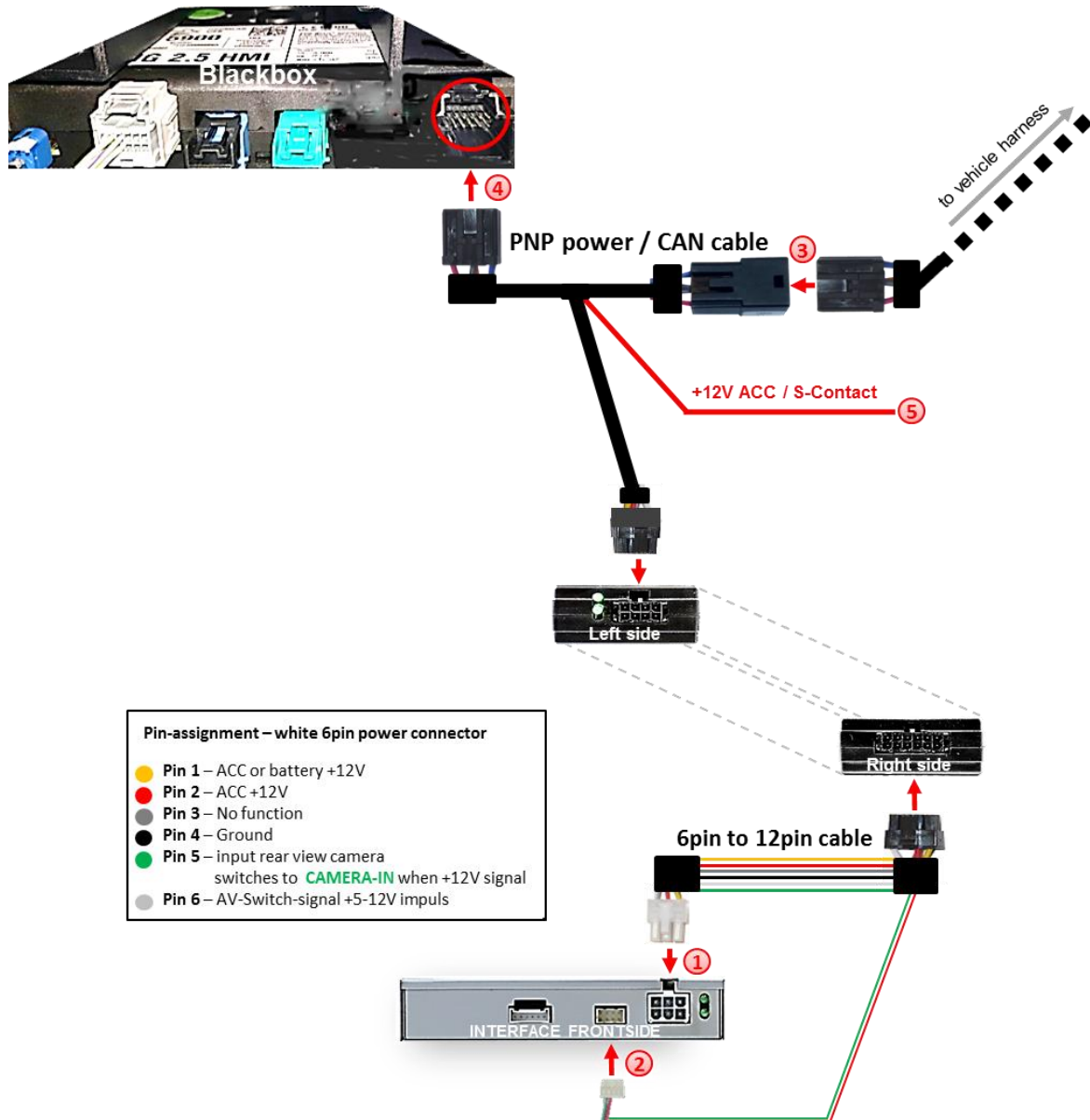

- 1 Connect the female 6pin connector of the 6 to 12pin cable to the 6pin connector of the video interface.
- 2 Connect the female 8pin connector of the communication cable to the 8pin connector of the video interface.
- 3 Remove the female 16pin connector of the vehicle harness from the rear-side of the blackbox and connect it to the male 16pin connector of the PNP Power / CAN cable.
- 4 Connect the opposite female 16pin connector of the PNP Power / CAN cable to the previously become free male 16pin connector at the rear-side of the blackbox.
- 5 Connect the single red wire „**Connect ACC**“ of the PNP Power / CAN cable to **+12V accessory power** or to **S-contact terminal 86s**.

Note: Check the interface’s LEDs after reconnecting the battery. One of them must light up.

2.4. Connection – picture signal cable

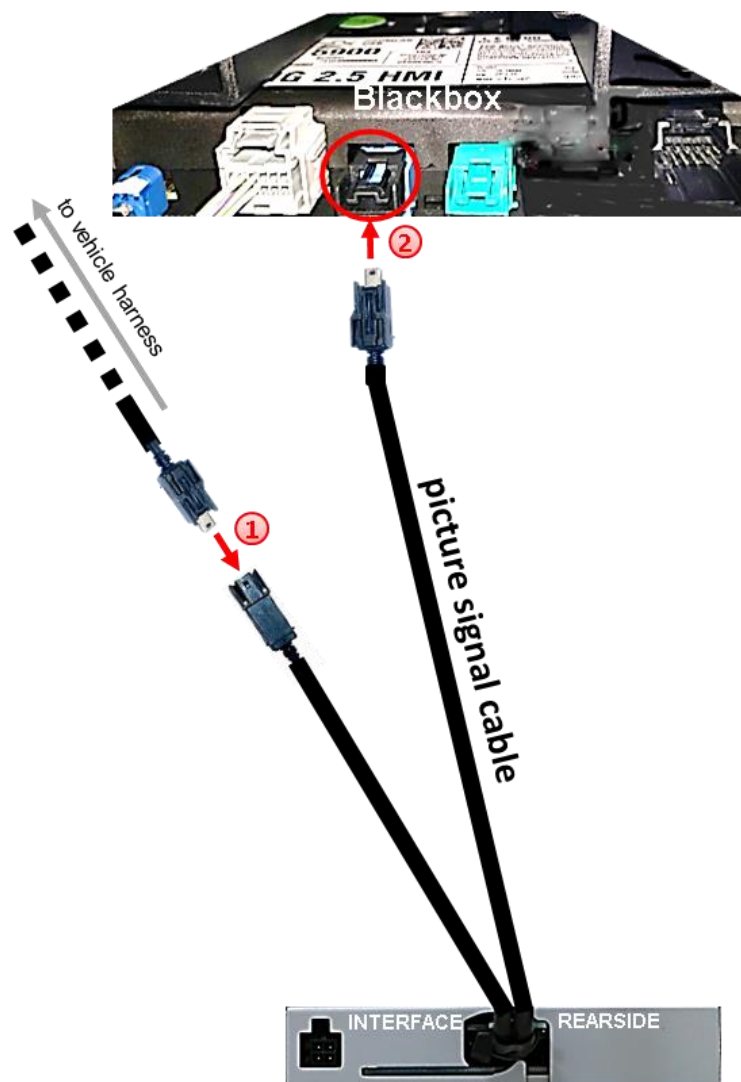

- 1 Remove the female Mini USB connector from the rear side of the blackbox and connect it to the male black Mini USB connector of the picture signal cable.
- 2 Connect the female black colored Mini USB connector of the picture signal cable to the previously become free male Mini USB connector at the rear side of the blackbox

2.5. Connecting video sources

It is possible to connect one after-market rear-view camera and two more Video sources to the video-interface.

Note: Before the final installation, we recommend a test-run to ensure the compatibility of the vehicle and the interface. Due to changes in the production of the vehicle manufacturer there's always a possibility of incompatibility.

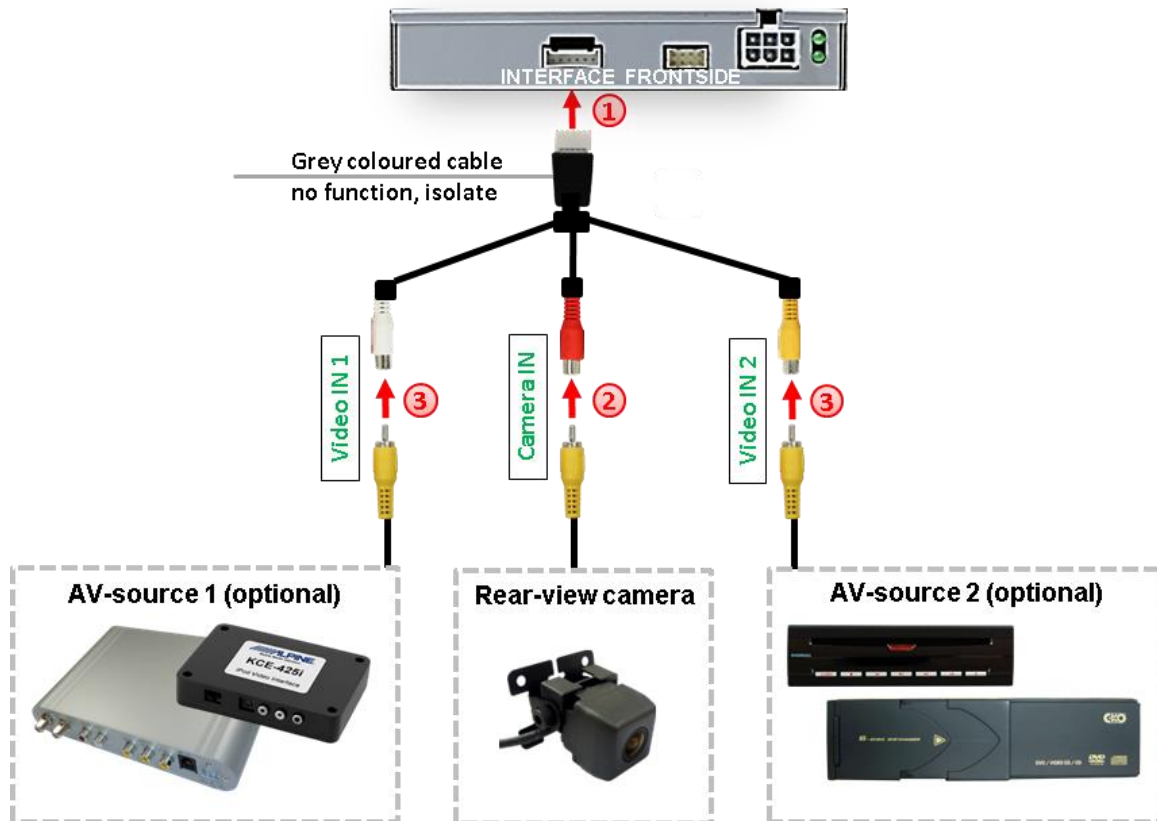

- 1 Connect the female 6pin connector of the video cable to the male 6pin connector of the video-interface.
- 2 Connect the video RCA connector of the rear-view camera to the female RCA connector "Camera-IN" of the video cable.
- 3 Connect the video RCA connectors of additional AV sources to the female RCA connectors "Video IN 1" and "Video IN 2".

2.5.1. After-market rear-view camera

Some vehicles have a different reverse gear code on the CAN-bus which the included CAN-box is not compatible with. In this case there are two different ways of installation. If the CAN-box is able to detect an enabled vehicle's reverse gear, the green wire of the 6pin to 12pin cable should carry +12V while the reverse gear is engaged.

Note: Do not forget to set dip5 of video-interface to ON before testing.

2.5.1.1. Case 1: CAN-box receives the reverse gear signal

If the CAN-bus box delivers +12V on the green wire of the 6pin to 12pin cable while reverse gear is engaged, the video interface will automatically switch to the rear-view camera input "CAMERA-IN" while the reverse gear is engaged.

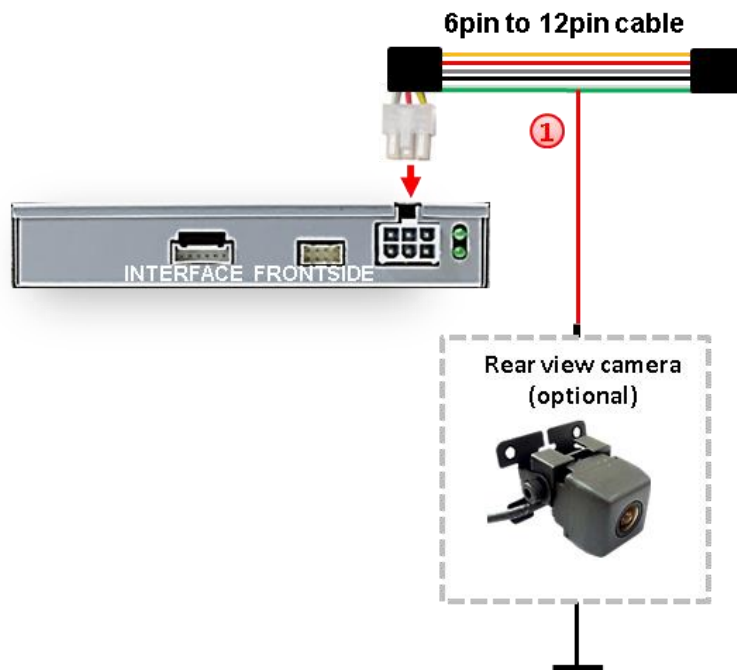

- ① Additionally, the +12V (max. 500mA) power supply for the rear-view camera can be taken from the green wire of the 6pin to 12pin cable.

2.5.1.2. Case 2: CAN-box does not receive the reverse gear signal

If the CAN-bus interface does not deliver +12V on the green wire of the 6pin to 12pin cable when reverse gear is engaged (not all vehicles are compatible) an external switching signal from the reverse gear light is required. As the reverse gear light signal contains electronic interference, a traditional open relay (e.g AC-RW-1230 with wiring AC-RS5) or filter (e.g. AC-PNF-RVC) is required. Below schema shows the use of a relay (normally open).

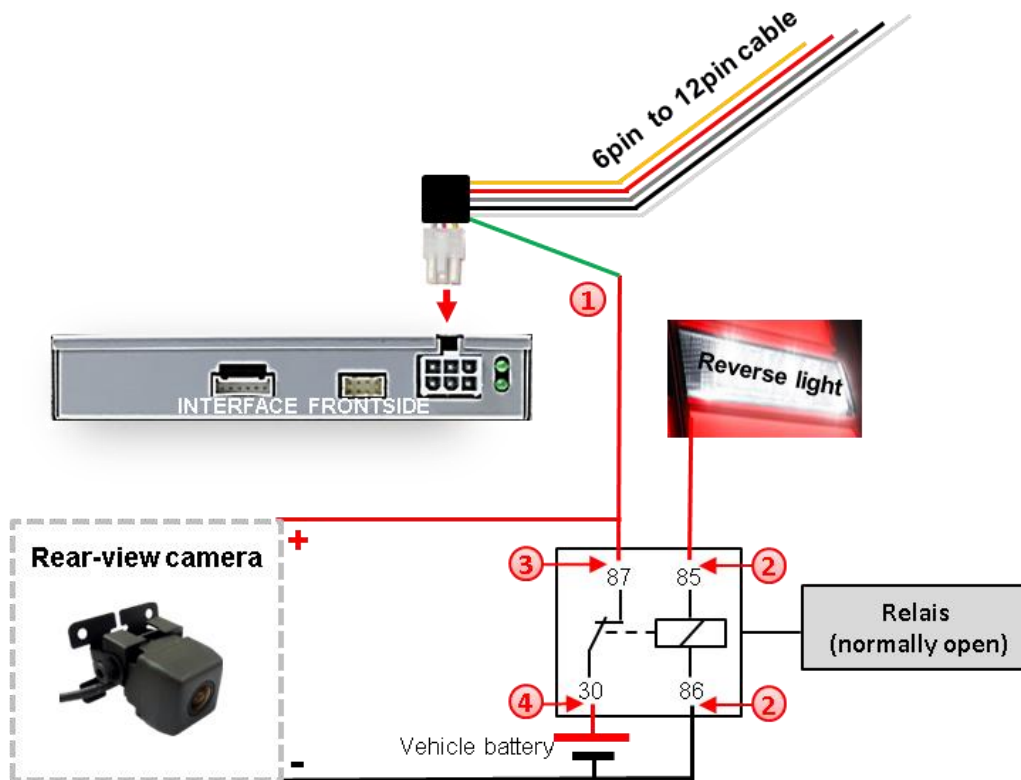

- ① Connect the green cable of the 6pin to 12pin cable to the output connector (87) of the relay.
- ② Connect the Reverse light's power-cable to coil (85) and the vehicle's ground to coil (86) of the relay.
- ③ Connect the output connector (87) of the relay to the rear-view camera's power-cable, like you did it with the green cable before.
- ④ Connect permanent power +12V to the relay's input connector (30).

Note: Don't forget to set the Dip 5 to ON.

2.5.2. Audio Insertion

This interface can only insert video signals into the factory infotainment. If an AV-source is connected, audio insertion must be done by factory audio AUX input or FM-modulator. The inserted video-signal can be activated simultaneously to each audio-mode of the factory infotainment.

2.6. Connection Video Interface and external keypad

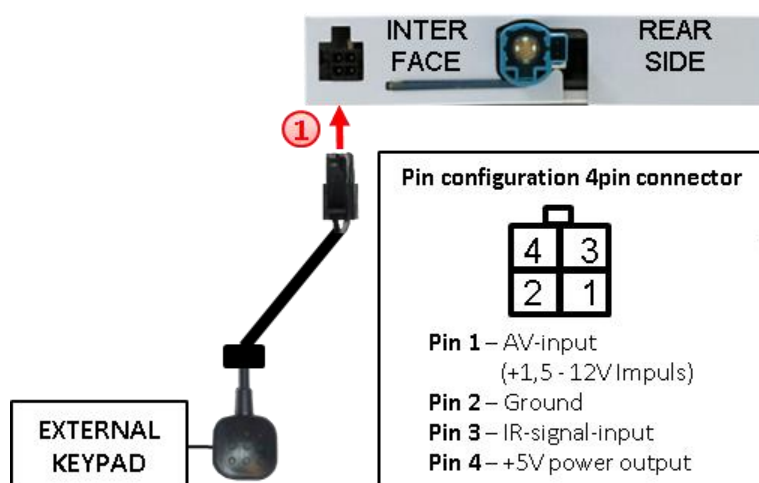

- 1** Connect the 4pin female connector of the external keypad to the male 4pin connector of the video interface.

Note: Regardless if it'll be used or not, the external keypad should always be connected! In case of non-using, it should be invisibly hidden together with the video interface.

2.7. Picture settings and guide lines

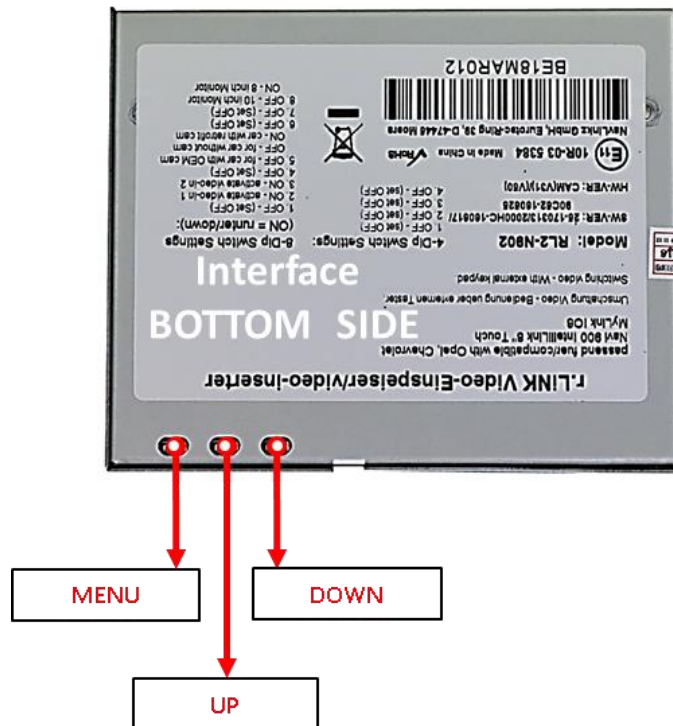

The picture settings are adjusted by the 3 buttons on the video-interface. Press the MENU button to open the OSD settings menu or to switch to the next menu item. Press UP and DOWN changes the selected value. The buttons are embedded in the housing to avoid accidental changes during or after the installation. Picture settings have to be done separately for AV1, AV2 and CAMERA-IN while the corresponding input is selected and visible on the monitor.

Note: The OSD menu is only shown when a working video source is connected to the selected video-input of the interface.

The following settings are available:

- Contrast
- Brightness
- Saturation
- Position H (horizontal)
- Position V (vertical)
- IR-AV1/2 (no function)
- Guide L/R (no function)
- UI-CNTRL (ON/OFF) guide lines
- Size H/V (picture size horizontal/vertical)

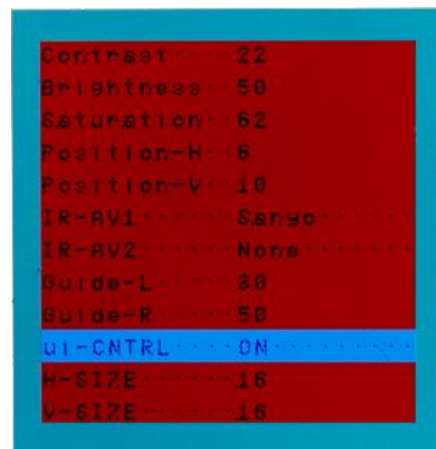

Note: If the CAN-box does not support the vehicle's CAN, the guide-lines cannot be used.

3. Switching the video sources

3.1. By infotainment button



Switching the video sources can be done by pressing the vehicle's „Call-off“ button.

Each press will switch to the next enabled input. If all inputs are enabled the order is:

Factory video → video IN1 → video IN2 → factory video →...

Disabled inputs will be skipped.

Switchover by vehicle buttons isn't possible in all vehicles. In some vehicles the external keypad has to be used.

3.2. By external keypad

The interface's **keypad** can be used to execute interface functions.

Short press keypad to switch the video-source.

Each repetition will switch to the next enabled input. Inputs which are not enabled are skipped.

Note: Alternatively or additionally, the white wire of the 6pin cable can be used with a +5-12V pulse to switch the video-sources alternatively.

4. Specifications

BATT/ACC range	7V - 25V
Stand-by power drain	55mA
Power consumption	360mA
Video input	0.7V - 1V
Video input formats	NTSC / PAL
Temperature range	-40°C to +85°C
Dimensions video-box	113 x 22 x 104 mm (W x H x D)
Dimensions CAN-box	73 x 22 x 30 mm (W x H x D)

5. FAQ – Trouble shooting Interface functions

For any troubles which may occur, check the following table for a solution before requesting support from your vendor.

Symptom	Reason	Possible solution
No picture/black picture (factory picture).	Not all connectors have been reconnected to factory head-unit or monitor after installation.	Connect missing connectors.
	No power on CAN-bus box (all LED CAN-bus box are off).	Check power supply of CAN-bus box. Check CAN-bus connection of CAN-bus box.
	CAN-bus box connected to CAN-bus in wrong place.	Refer to the manual where to connected to the CAN-bus. If not mentioned, try another place to connect to the CAN-bus.
	No power on video-interface (all LED video-interface are off).	Check whether CAN-bus box delivers +12V ACC on red wire output of 8pin to 6pin cable. If not cut wire and supply ACC +12V directly to video-interface.
No picture/black picture/white picture (inserted picture) but factory picture is OK.	No picture from video source.	Check on other monitor whether video source is OK.
	No video-source connected to the selected interface input.	Check settings dips 1 to 3 of video interface which inputs are activated and switch to corresponding input(s).
	LVDS cables plugged in wrong place.	Double-check whether order of LVDS cables is exactly connected according to manual. Plugging into head-unit does not work when the manual says to plug into monitor and vice versa.
Inserted picture totally wrong size or position.	Wrong monitor settings of video-interface.	Try different combinations of dips 7 and 8 of video-interface. Unplug 6pin power after each change.
Inserted picture double or 4 times on monitor.		
Inserted picture distorted, flickering or running vertically.	Video sources output set to AUTO or MULTI which causes a conflict with the interfaces auto detection.	Set video source output fixed to PAL or NTSC. It is best to set all video sources to the same standard.
	If error occurs only after source switching: Connected sources are not set to the same TV standard.	Set all video sources to the same standard.
	Some interfaces can only handle NTSC input.	Check manual whether there is a limitation to NTSC mentioned. If yes, set source fixed to NTSC output.
Inserted picture b/w.	Picture settings have not been adjusted.	Use the 3 buttons and the interface's OSD to adjust the picture settings for the corresponding video input.
Inserted picture qual. bad.		
Inserted picture size slightly wrong.		
Inserted picture position wrong.		
Camera input picture flickers.	Camera is being tested under fluorescent light which shines directly into the camera.	Test camera under natural light outside the garage.
Camera input picture is bluish.	Protection sticker not removed from camera lens.	Remove protection sticker from lens.

Symptom	Reason	Possible solution
Camera input picture black.	Camera power taken directly from reverse gear lamp.	Use relay or electronics to "clean" reverse gear lamp power. Alternatively, if CAN-bus box is compatible with the vehicle, camera power can be taken from green wire of 6pin to 8pin cable.
Camera input picture has distortion.		
Camera input picture settings cannot be adjusted.	Camera input picture settings can only be adjusted in AV2 mode.	Set dip 3 of video-interface to ON (if not input AV2 is not already activated) and connect the camera to AV2. Switch to AV2 and adjust settings. Reconnect camera to camera input and deactivate AV2 if not used for other source.
Graphics of a car in camera input picture.	Function PDC is ON in the interface OSD.	In compatible vehicles, the graphics will display the factory PDC distance. If not working or not wanted, set interface OSD menu item UI-CNTRL to ALLOFF.
Chinese signs in camera input picture	Function RET or ALL is ON (function for Asian market) in the interface OSD.	Set interface OSD menu item UI-CNTRL to ALLOFF or PDCON.
Not possible to switch video sources by OEM button.	CAN-bus interface does not support this function for vehicle.	Use external keypad or cut white wire of 6pin to 8pin cable and apply +12V impulses for AV-switching.
Not possible to switch video sources by external keypad.	Pressed too short.	For video source switching a longer press of about 2.5 seconds is required.
	SW-version of interface does not support external keypad.	Use OEM-button or cut white wire of 6pin to 8pin cable and apply +12V impulses for AV-switching.
Interface does not switch to camera input when reverse gear is engaged.	CAN-bus interface does not support this function for the vehicles.	Cut the green wire of the 6pin to 8pin cable and apply +12V constant from reverse gear-lamp signal. Use relay to "clean" R-gear lamp power.
Interface switches video-sources by itself.	CAN-bus interface compatibility to vehicle is limited.	Cut the grey wire of 6pin to 8pin and isolate both ends. If problem still occurs, additionally cut the white wire of 6pin to 8pin cable and isolate both ends.

6. Technical Support

Please note that direct technical support is only available for products purchased directly from NavLinkz GmbH. For products bought from other sources, contact your vendor for technical support.

NavLinkz GmbH
distribution/tech dealer-support
 Eurotec-Ring 39
 D-47445 Moers

Tel +49 2841 949970
 Email mail@navlinkz.de

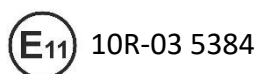

Made in China

